

ARIVO Cashless Payment Terminal

Cashless payment in less than 10 seconds

Open parking fees can be paid quickly and easily on site using our cashless payment terminal. Parking customers simply have to enter their license plate number and can conveniently pay by card.

Our cashless system, free of moving, maintenance-prone components, ensures a seamless parking space operation. Its intuitive user interface, bright display, and fast processing make it favored among people of all age groups.



Advantages

- ✔ **Comfortable, cashless payment**
In <10 seconds; by debit, credit card or mobile (via Apple or Google Pay)
- ✔ **Intuitive operation & modern design**
Thanks to the large display, simple design, streamlined menu navigation & visual feedback in the form of help texts
- ✔ **Redeem rewards**
Rewards easily redeemable via QR code scanner
- ✔ **Maintenance-free**
No maintenance-prone components such as receipt printers or coin trays for less effort in operation
- ✔ **Flexible installation**
By means of wall bracket or free-standing with stand; indoor & outdoor possible
- ✔ **Emergency call button & intercom system**
As a back-up & with VoIP function (any telephone number can be stored as an emergency number)

Simple operation for your parking customers

1. Enter licence plate number



2. Redeem rewards

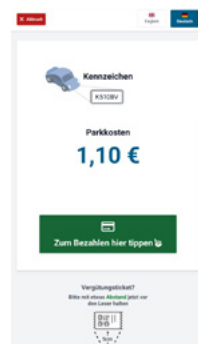

3. Pay with card



4. Scan invoice via QR code

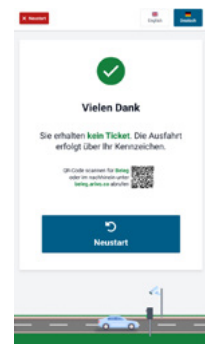

Mounting options for Arivo Cashless

The cashless payment terminal can be installed both **indoors** and **outdoors** with the right roofing. The terminal can be mounted either

- free-standing on a stand or
- via a wall bracket.



Technical information

- ➔ **Components:** Housing, touch display, emergency call button, intercom (microphone & loudspeaker), QR code reader, payment terminal, stand or wall bracket, power & network cabling
- ➔ **Screen diagonal:** 31,5"
- ➔ **Dimensions (H x B x T):** 52 x 22 x 106 cm
- ➔ **Weight:** 58 kg (85 kg with stand)
- ➔ **Color code of the housing:** RAL9016
- ➔ **Certification:** CE
- ➔ **Power supply:** AC 230V/50Hz max. 600mA
- ➔ **Maximum output:** 138W

Construction services provided by the customer

- ➔ **Foundation:** 50 x 50 and 50 cm deep
- ➔ **Piping & cabling:** According to Arivo cable diagram
- ➔ **Network connection:** CAT7
- ➔ **Roofing:** For outdoor installation

Dimensions of the cashless payment terminal with wall mount

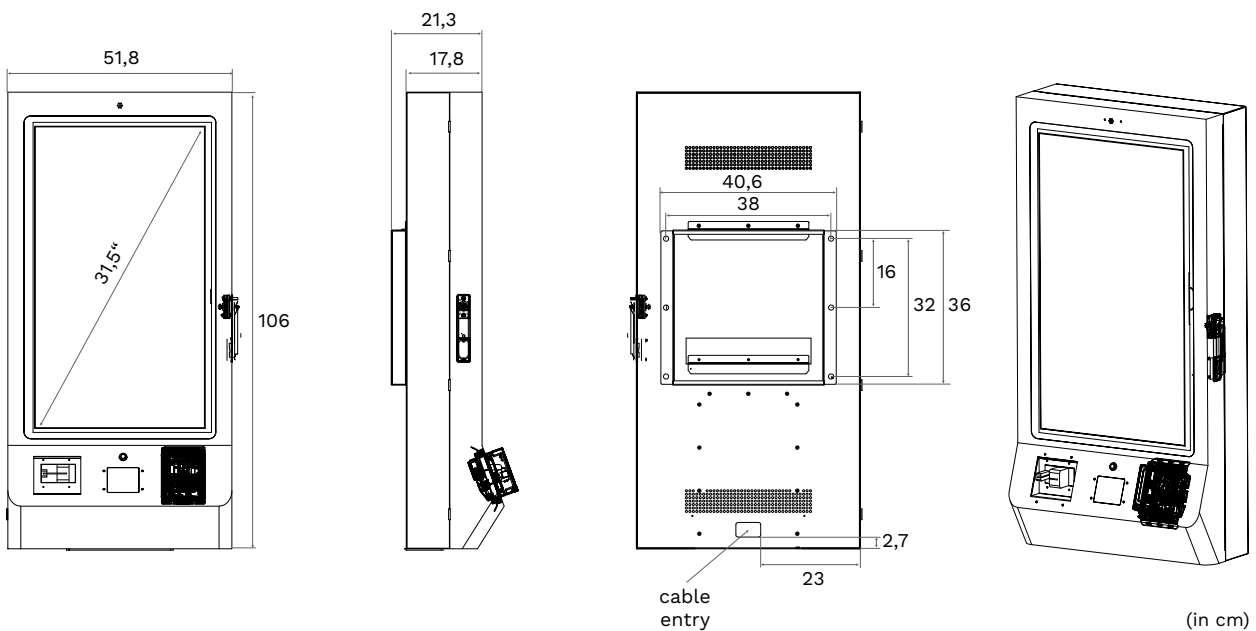

Dimensions of the cashless payment terminal with stand

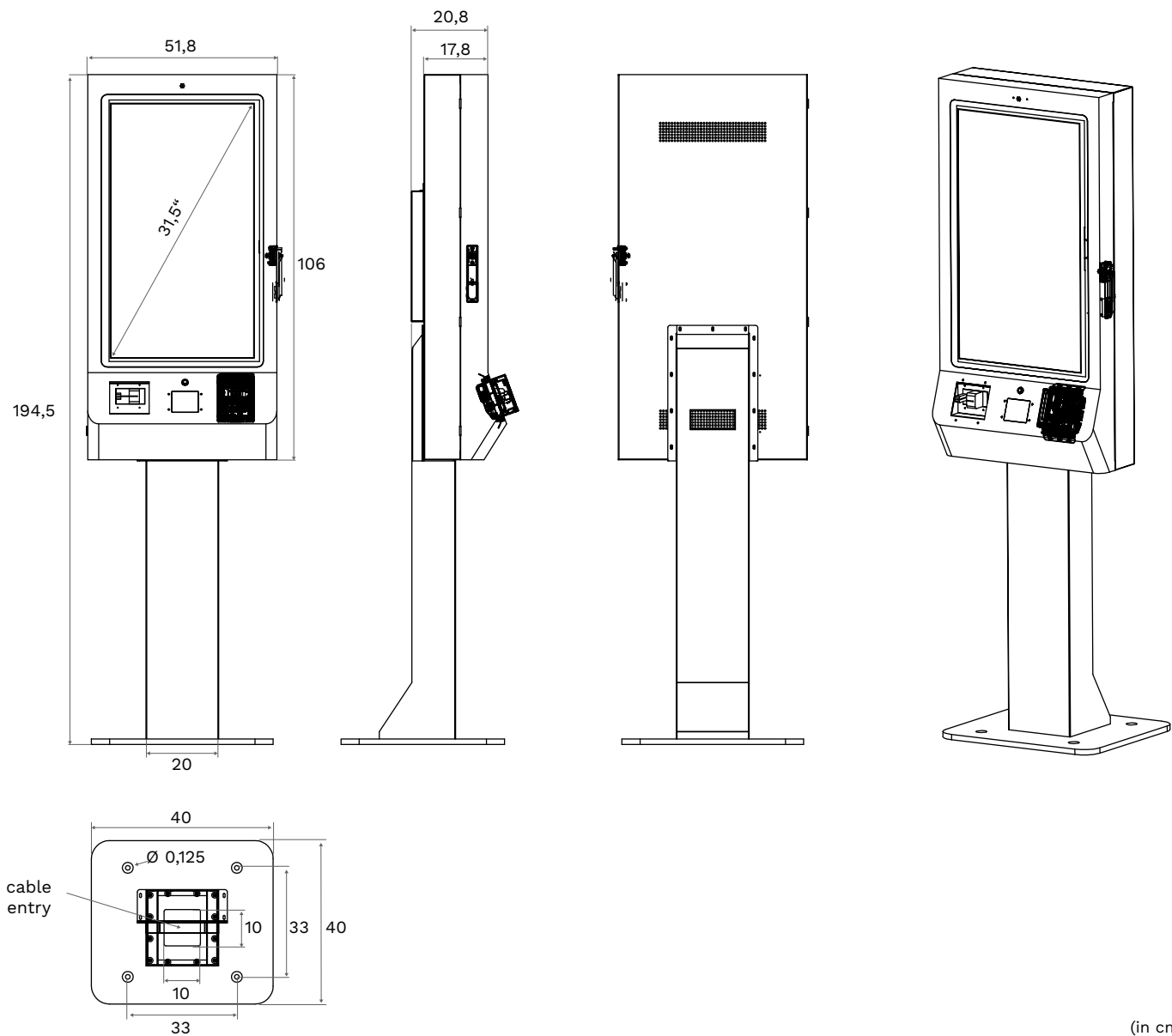

(in cm)